

Six-Component Force Sensor

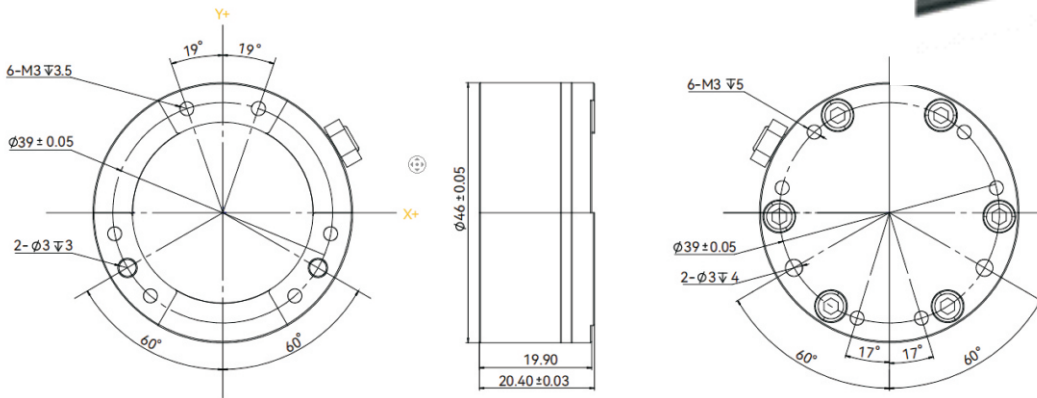

GMD305



FEATRUES

- Six-axis joint calibration, fully suppress crosstalk;
- Small high-precision six-axis force sensor, high overload, both high stiffness and high sensitivity.

PARAMETERS

Technical Index	GMD305A	GMD305B	GMD305C
Fx,Fy(N)	50	150	200
Fz(N)	50	150	200
Mx,My(Nm)	2	5	7
Mz(Nm)	2	5	7
Diameter(mm)	46	46	46
Height(mm)	20.4	20.4	20.4
Comprehensive Error	0.5%F.S	0.5%F.S	0.5%F.S
Resolution	0.03%F.S	0.03%F.S	0.03%F.S
Repeatability Error	0.1%F.S	0.1%F.S	0.1%F.S
Sampling Rate(Hz)	1000	1000	1000
Operating Temp Range(℃)	5~80	5~80	5~80
Supply Power(VDC)	9~24	9~24	9~24
Overload Level	300%F.S	300%F.S	300%F.S

PARAMETERS

Technical Index	GMD305A	GMD305B	GMD305C
Ingress Protection	IP64	IP64	IP64
Material	Aluminum alloy	Aluminum alloy	Aluminum alloy
Surface Treatment	Anodization	Anodization	Anodization
Weight(kg)	0.06	0.07	0.07
Communication	RS485/RS422/USB / Industrial Ethernet / MODBUS /TCP/UDP		

Note: Used together with high precision data acquisition system