

Digital Crane Scale

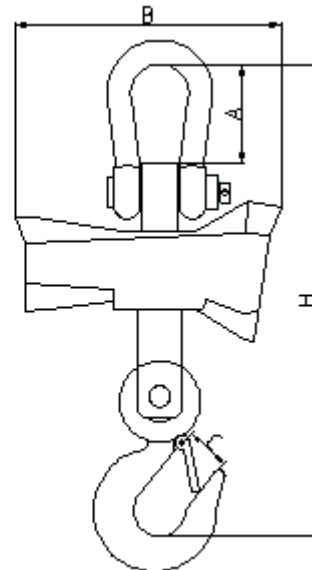

GSP910

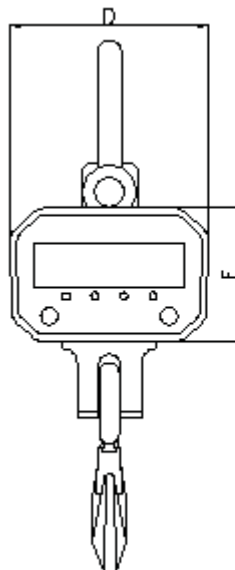

DIMENSIONS

Model	Cap.(kg)	A(mm)	B(mm)	C(mm)	D(mm)	E(mm)	H(mm)	G.W.(kg)
GSP910-2	2000	95	260	35	195	130	430	12
GSP910-3	3000	95	260	45	195	130	460	13
GSP910-5	5000	125	325	55	235	158	525	19
GSP910-10	10000	140	325	65	235	158	660	29
GSP910-15	15000	175	345	70	235	160	805	57
GSP910-20	20000	175	345	85	235	160	870	63

FEATURES

- NEMA 12/IP54 powder coated Foundry Cast Aluminum;
- Large red 5 digit LED display (digit height 30mm), Kg, lb,N are selectable, kg are default unit;
- Tare, Zero, Auto zero tracking, Total, Hold, Overload warning and record, operated through infrared remote controller;
- Special design load cell, threadless connection, more safety;
- Battery Operated with low battery indication, Automatic turn off , power-saving function;value;

SPECIFICATIONS

Model	Max.weight(kg)	Min.weight(kg)	Interval(kg)	number of divisions(n)
GSP910-2	2000	20	1	2000
GSP910-3	3000	20	1	3000
GSP910-5	5000	40	2	2500
GSP910-10	10000	100	5	2000
GSP910-15	15000	100	5	3000
GSP910-20	20000	200	10	2000

MAIN TECHNICAL DATA

Accuracy Standard	According to OIML class III
Display	30mm (1.2") 5 digits LCD or LED
Zero Range	4% F.S.
Tare Range	20% F.S.
Overload Indication	100% F.S. + 9e
Max. Safety Load	125% F.S.
Ultimate Load	400% F.S.
Battery Type	Fully sealed Lead-Acid battery, 6V/4.5Ah
Battery Life	≥50 hours
Adapter	DC 9V/1000mA
Operating Temperature Range	- 10℃ ~ + 40℃
Operating Humidity	≤85% RH under 20℃
Remote Controller Distance	Max. 15m
Battery of Remote Controller	7# battery, 1.5V x2