

GSP908 (30kg~300kg)

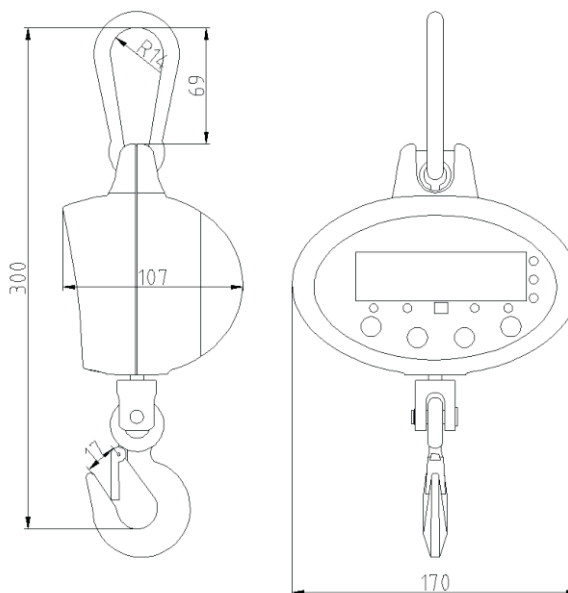

FEATURES

- Engineering plastic case, strong and durable, the hook adopts 360° design, easy to use;
- Large red 5 digit LED display (digit height 20mm), Kg, lb,N are selectable, kg are default unit;
- Tare, Zero, Auto zero tracking, Total, Hold, Overload warning and record, operated through infrared remote controller;
- Battery Operated with low battery indication, Automatic turn off , power-saving function;
- The acceleration of gravity can be regulated through remote controller according to different places value;

SPECIFICATIONS

Model	Max.weight(kg)	Min.weight(kg)	Interval(kg)	number of divisions(n)	G.W.(kg)
GSP908-003	30	0.2	0.01	3000	0.95
GSP908-005	50	0.4	0.02	2500	0.95
GSP908-01	100	1	0.05	2000	0.95
GSP908-015	150	1	0.05	3000	0.95
GSP908-02	200	2	0.1	2000	0.95
GSP908-03	300	2	0.1	3000	0.95

MAIN TECHNICAL DATA ///

Accuracy Standard	According to OIML class III
Display	20mm (0.8") 5 digits LCD or LED
Zero Range	4% F.S.
Tare Range	20% F.S.
Overload Indication	100% F.S. + 9e
Max. Safety Load	125% F.S.
Ultimate Load	300kg is 300% range, the other is 400% range
Battery Type	Fully sealed Lead-Acid battery, 4V/2Ah
Battery Life	≥80 hours
Adapter	DC 4V/500mA
Operating Temperature Range	- 20°C ~ + 50°C
Operating Humidity	≤85% RH under 20°C
Remote Controller Distance	Max. 15m
Battery of Remote Controller	7# battery, 1.5V x 2